

GRITECSA

SINGER FURNACES ECONOMIZERS



GRITECSA

Pol. Ind. Sot dels Pradals
C/ Camí de la Tolosa, 15 - 08500 Vic
Tel. 93 883 36 44 - Fax 93 885 14 47
e-mail. gritecsa@gritecsa.com
www.gritecsa.com

APPLICATION

Singer furnace for hair removal and as a decontaminant or sanitary at the end of the sacrifice line. Specific furnace to improve faces and ears.

DESCRIPTION

- **Furnaces are manufactured entirely in stainless steel.**
- **Equipped with fans, they work with a gas / air mixing system that optimizes gas consumption, improves the dehairing of the animal and reduces the maintenance of the burners.**
- **Fully automatic operation through photoelectric cells that detect the entrance of the animal.**
- **Flame detection by UV cell that improves the reliability of the equipment.**
- **Operating time easily adjustable.**
- **Equipped with special nozzles to improve the finish of the head.**
- **Easy installation and maintenance.**
- **Available in Natural Gas, LPG and Butane.**
- **It works with pressure inlet gas from 100 mbar.**
- **Optional bell fume collection and gas train valves.**
- **Optional economizer to recover hot gases.**



MODEL	GRIT-1	GRIT-2	GRIT-3	GRIT4
Production	600 pigs/h	1.000 pigs/h	600 pigs/h	600 pigs/h
Nº Burners	56	56	28	24
Nº Columns	4	4	2	2
Power	1.745 kW	1.745 kW	870 kW	830 kW
Stages	1	2	1	1
Flame detection	U.V.	U.V.	U.V.	U.V.
Widht	1.528 mm	1.528 mm	1.720 mm	1.720 mm
Large	1.513 mm	1.998 mm	1.110 mm	1.100 mm
Height	3.155 mm	3.155 mm	2.415 mm	2.415 mm
Power supply	3,0 kW	3,0 kW	1,0 kW	1,0 kW
Weight	1.500 kg	1.800 kg	750 kg	750 kg
Control	Conventional	PLC	Conventional	Conventional

GRIT-1



MODEL	GRIT-1
Production/d	600 pigs/h
Nº Burners	56
Nº Columns	4
Power	1.745 kW
Stages	1
Flame detection	U.V.
Widht	1.528 mm
Large	1.513 mm
Height	3.155 mm
Power supply	3,0 kW
Weight	1.500 kg
Control	Conventional

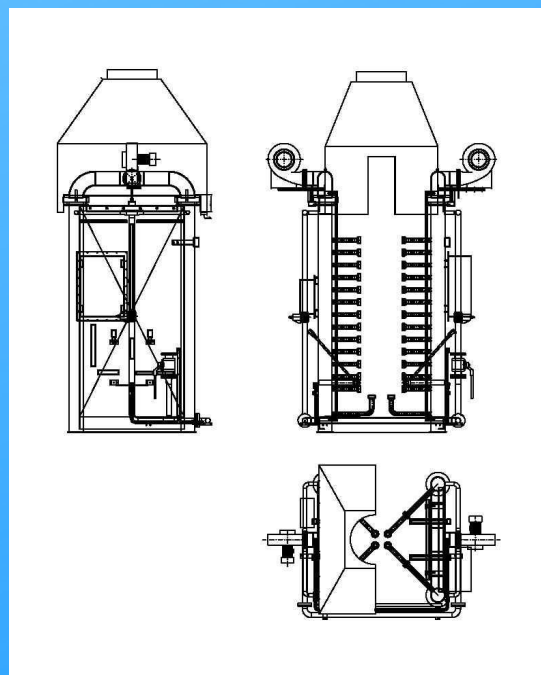

GRIT-2

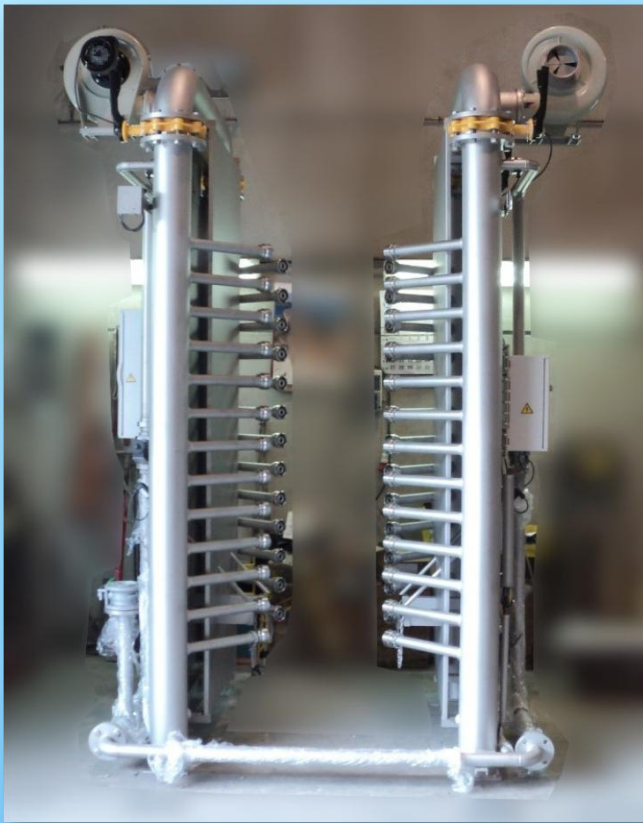

MODEL	GRIT-2
Production	1.000 pigs/h
Nº Burners	56
Nº Columns	4
Power	1.745 kW
Stages	2
Flame control	U.V.
Widht	1.528 mm
Large	1.998 mm
Height	3.155 mm
Power supply	3,0 kW
Weight	1.800 kg
Control	PLC

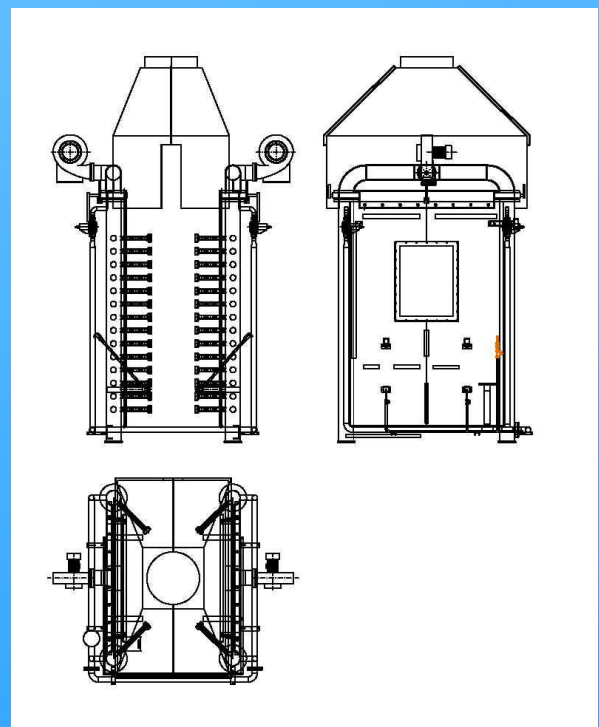
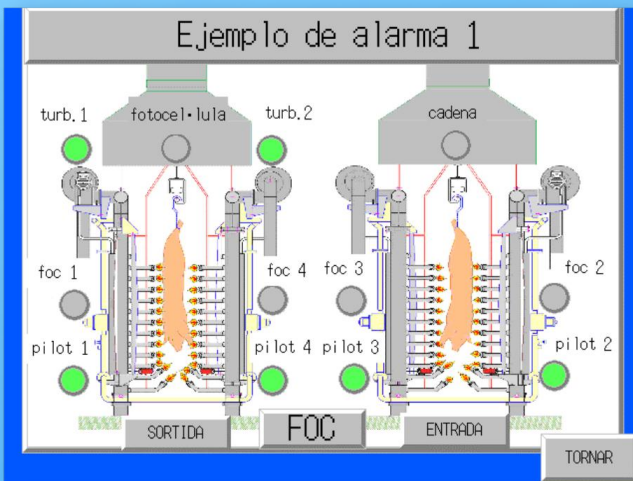

GRIT-3



MODEL	GRIT-3
Production	600 pigs/h
Nº Burners	28
Nº Columns	2
Power	970kW
Stages	1
Flame control	U.V.
Widht	1.720 mm
Large	1.110 mm
Height	2.415 mm
Power supply	1,0 kW
Weight	750 kg
Control	Conventional

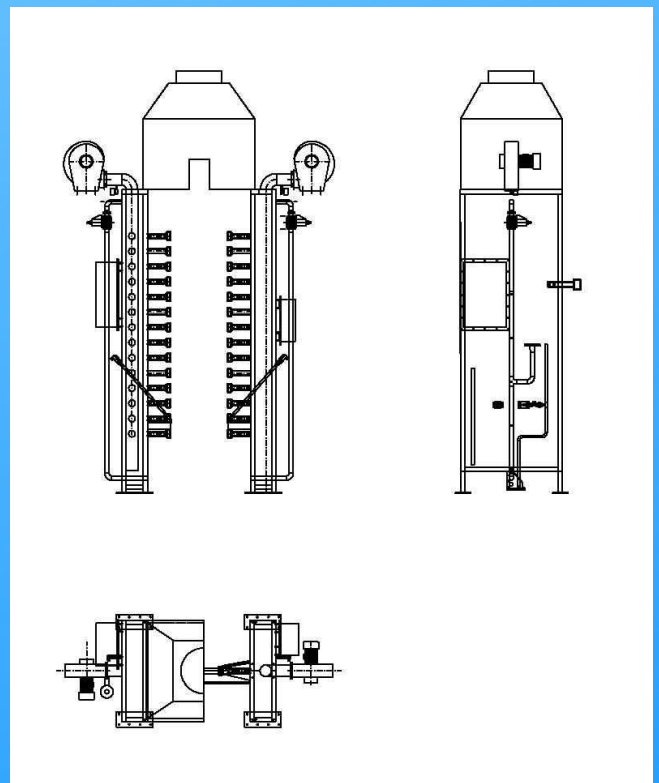

GRIT-4



MODEL	GRIT-4
Production	600 pigs/h
Nº Burners	24
Nº Columns	2
Power	830 kW
Stages	1
Flame control	Cél.lula UV
Widht	1.720 mm
Large	1.110 mm
Height	2.415 mm
Power supply	1,0 kW
Weight	750 kg
Control	Conventional

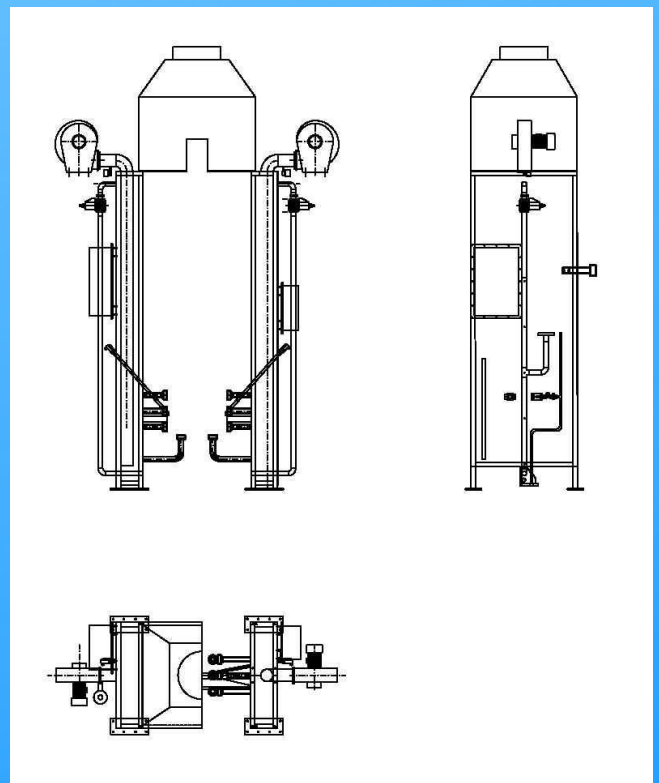

ECONOMIZERS

APPLICATION

Recovery of residual heat from the flue gases of the singeing furnace.

DESCRIPTION

- **Gas/water exchanger made entirely of stainless steel.**
- **Easily adaptable to the chimney of the singeing furnace.**
- **Different possibilities of use: DHW production, scald heating, etc. with water at temperature up to 80°C.**
- **Possibility of supplying pump skids adapted to the needs of each installation.**
- **Quickly amortizable due to the high percentage of heat recovery.**



ECONOMIZER VIEWS

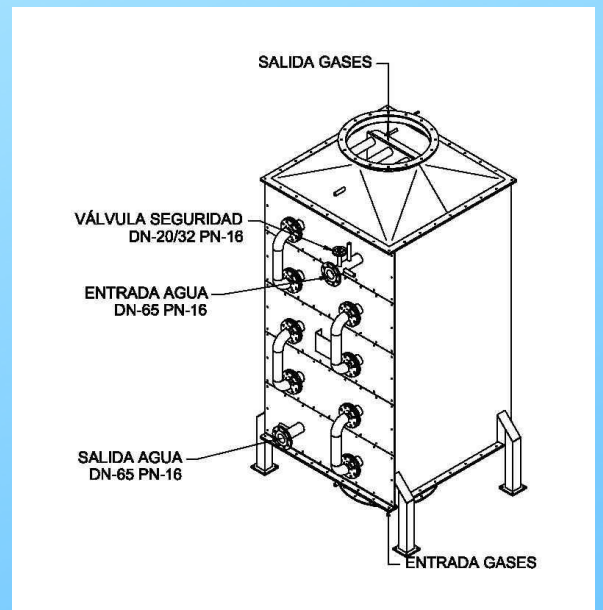
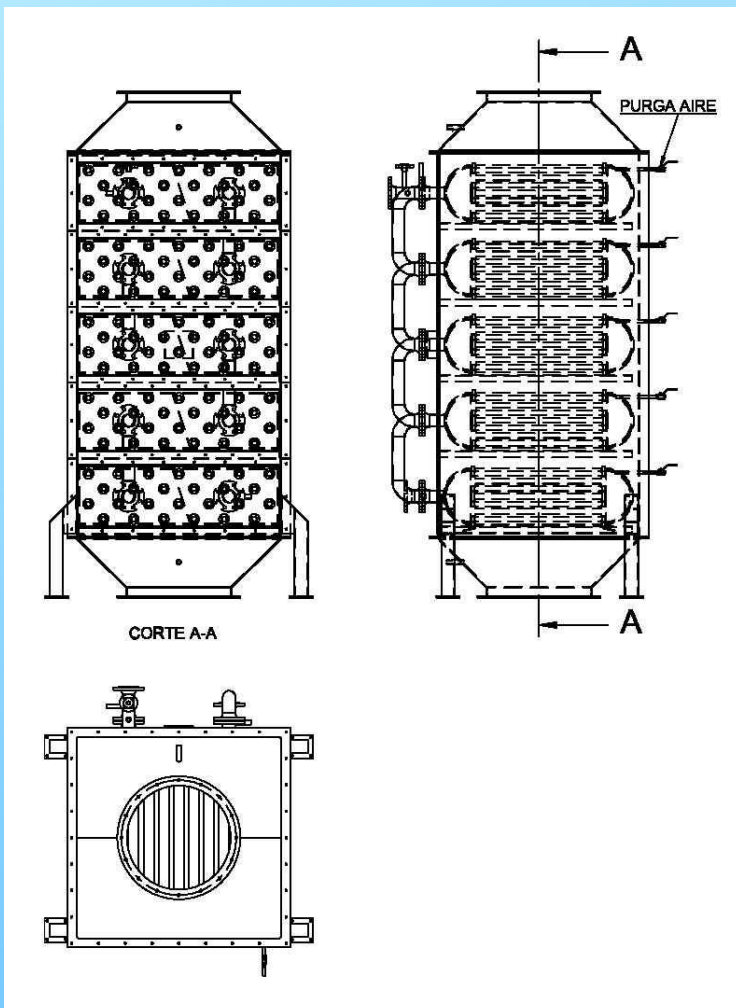

TECHNICAL CHARACTERISTICS

Dimensions	1330 x 1310 x 3018 mm
Weight	900 Kg
Gases Connection diameter	600 mm
Heat recovery on burned heat	10%
Max DHW production temperature	80°C

GRITECSA

Pol. Ind. Sot dels Pradals
C/ Camí de la Tolosa, 15 - 08500 Vic
Tel. 93 883 36 44 - Fax 93 885 14 47
e-mail. gritecsa@gritecsa.com
www.gritecsa.com